



Glock Installation

For R3D™ 2.0 Sets

Included Components

1. Front Sight
2. Front Sight Screw
3. Rear Sight
4. Glock® Install Tool
5. Red Tread Locker

Tools Needed

- Hammer
- Brass or Delrin Punch
- Alcohol
- Q-tips
- Pliers
- File

Before installing or adjusting your sights, unload and check to ensure the firearm is unloaded.

1 Remove slide from frame per owner's manual instructions

2 Remove existing sights*

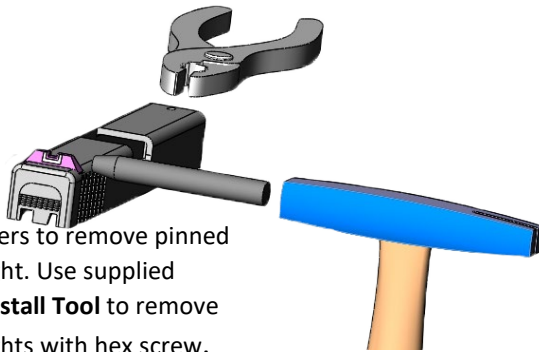

3 Degrease slide and the sight contact surfaces

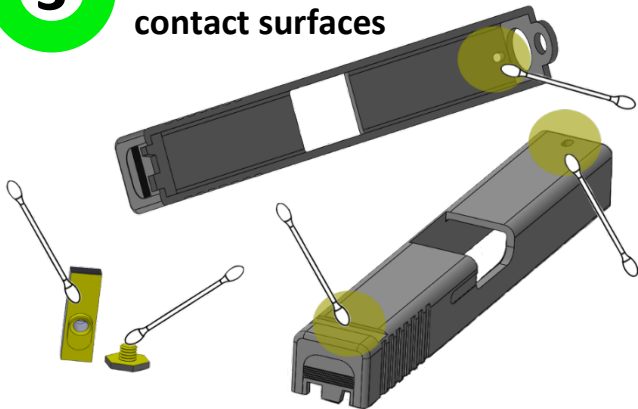

4 Test fit front sight

5 Apply Red threadlocker to the bottom of the sights and to the screw threads

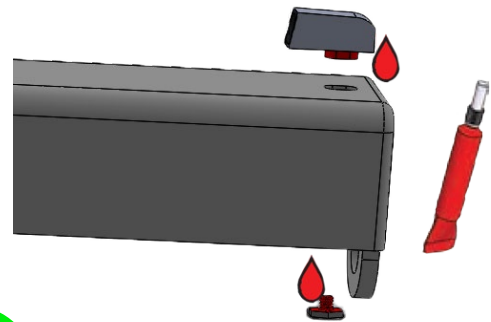

6 Assemble the front sight*

* Only tighten screw to fingertip tight, over tightening will shear off the screw head.

7 Check sight alignment

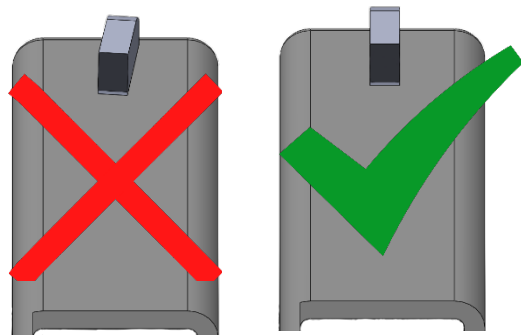

8

Secure slide in a stable holding device

9

Push sight into the dovetail as far as it will go with finger pressure*

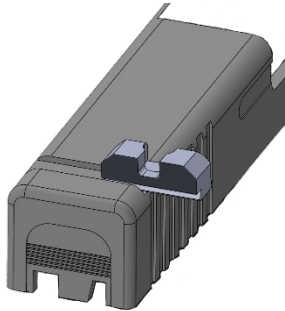

* The sight should slide 1/4th to 1/3rd of the way in

If it does not, file as needed until the sight presses in 1/3rd of the way into the dovetail

Run the bottom of the sights on a level file two times

Turn the sight 180° and run them down another two times

Test fit the sights and repeat filing steps if necessary

10

Drive the rear sights into the dovetail until the notch is centered on the slide*

*When driving sights into the dovetail ensure the punch is positioned on the sights dovetail (male dovetail)

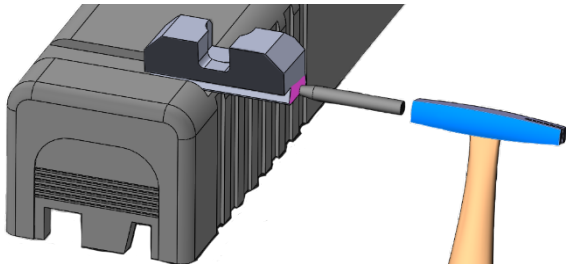

11

Apply threadlocker to all sides of the rear sights*

*Do not apply thread locker to set screw holes

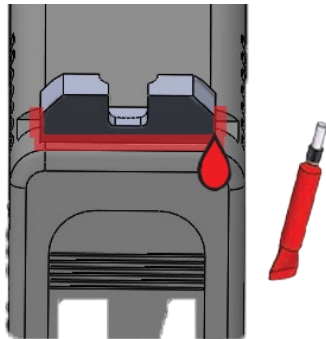

12

Let threadlocker set for 15+ minutes

13

Lightly wipe off excess threadlocker with a Q-tip*

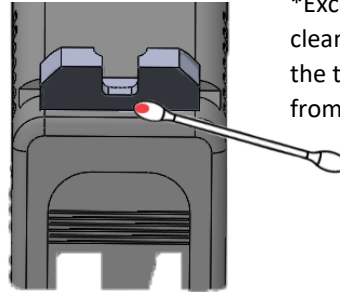

*Excessive cleaning can pull the threadlocker from joint

14

Let threadlocker and sights cure for 24 hours before shooting the firearm

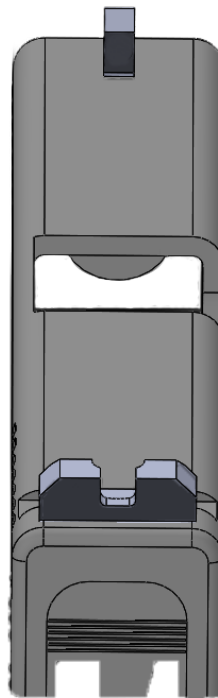

Pro Tip: Zero your sights before applying threadlocker to the rear sight

Many shooters like to fine tune their sight at the range, it's okay to shoot a few rounds to ensure your sights are zeroed before locking them into position

Our sights have lasted through 10,000 round shoot testing when installed correctly. Please use the threadlocker liberally to ensure the sights do not vibrate loose or come out.

15

Wipe sights down with protective oil in a light coating to prevent potential rust issues.