

## LCR Installation

Verify correct caliber fit (.38/.357 or 9mm/.22)  
Gunsmith Installation Recommended

### Included

Front Sight



Blue Thread Locker



1/16" Drift Punch



Must slip through the hole of the XS Sight

Hammer



Pliers & Pads



Alcohol



Acetone, gunscrubber, brake cleaner, etc.

Q-tips (5-10)

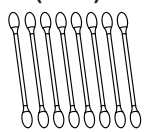

**Before installing or adjusting your sights, unload and/or check to ensure the firearm is unloaded.**

### 1 Remove Factory Retaining Pin

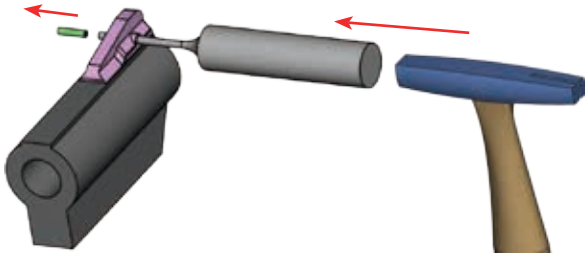

### 4 Degrease Tenon and XS® Sight

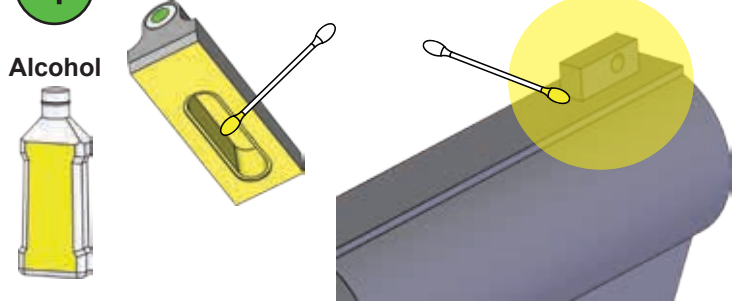

### 2 Remove Factory Front Sight

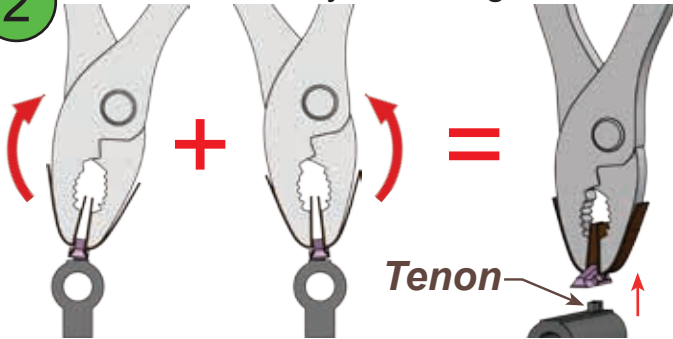

### 5 Test Fit XS® Sight on Barrel

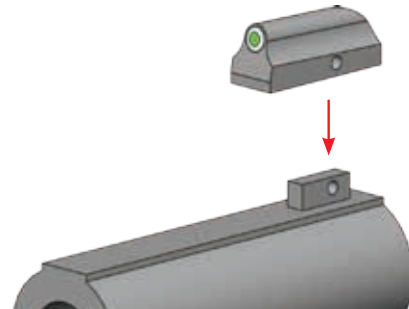

**WARNING!** Be careful not to break the Tenon under the sight. Lightly wiggle slowly back and forth.

XS® Sight should fit completely over the tenon onto the barrel with less than a .005" gap.

### 3 Remove any leftover adhesive or debris.

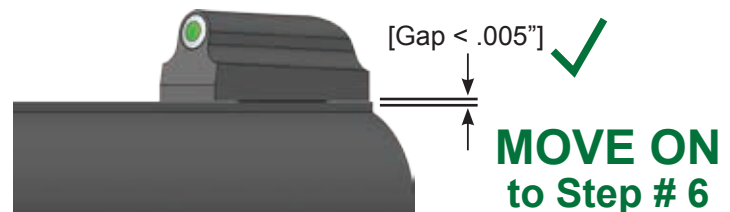

Take good care not to mark the barrel's finish.

6 Apply Blue Thread Locker to Front Sight & the Tenon

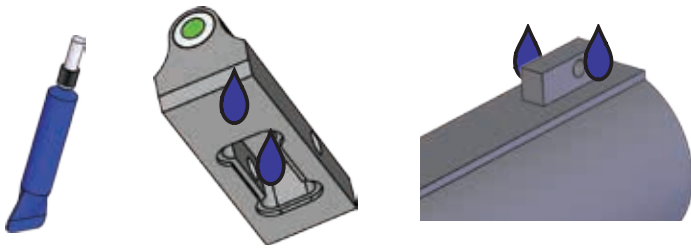

7 Press XS® Sight down and drive in Retaining Pin

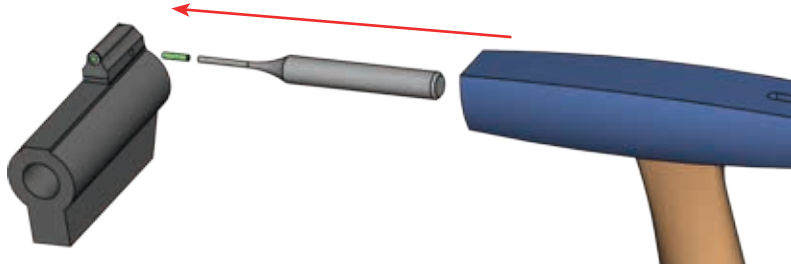

*"Make sure Sight is pressed all the way down."*

8 Check Alignment (Re-Check at the End)



9 Wipe Excess Blue Thread Locker & Recheck Alignment

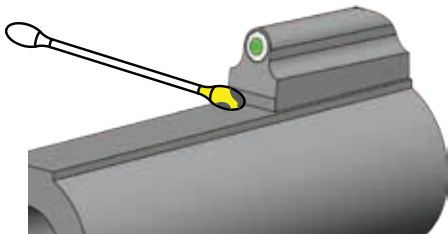

10 Let Blue Thread Locker cure for 2 hours before shooting then wipe sights down with protective oil in a light coating to prevent potential rust issues.